

Sonus

Sonus panels are high density gypsum board with continuous sound absorbing perforations for a monolithic appearance. They can be used on ceilings, walls and special applications where noise reduction is critical. Sonus panels come in many perforation designs, some with random patterns, some with sequential patterns. The perforated board absorbs and diffuses sound that would otherwise reflect back into the room.

SONUS SQUARE 12/25

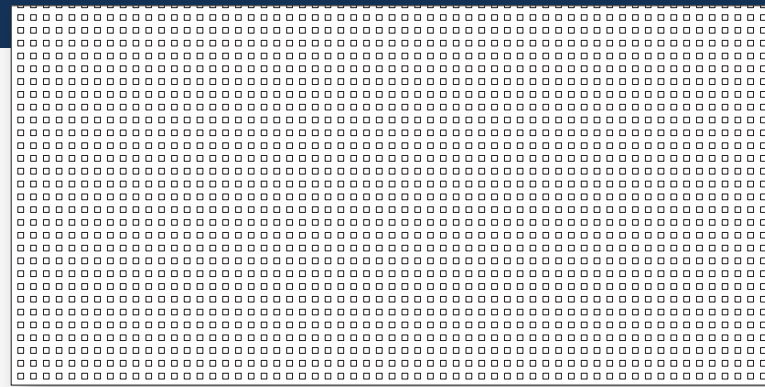

PERFORMANCE

- A 2-21, D0 (non-flammable) according to DIN EN 13501**
- Maximum Relative Humidity: 70%**
- Recycled Content: 86% (3% Post Consumer)**
- NRC: Up to .85**

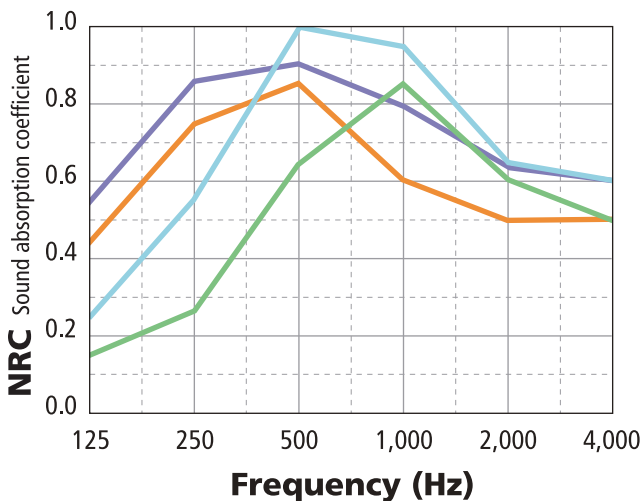

Cavity Depth 2" Felt Only	0.15	0.25	0.65	0.85	0.60	0.50
Cavity Depth 8" Felt Only	0.45	0.75	0.85	0.60	0.50	0.50
Cavity Depth 2" with 2" fiberglass	0.25	0.55	1.00	0.95	0.65	0.60
Cavity Depth 8" with 2" fiberglass	0.55	0.85	0.90	0.80	0.65	0.60

100% size to show pattern

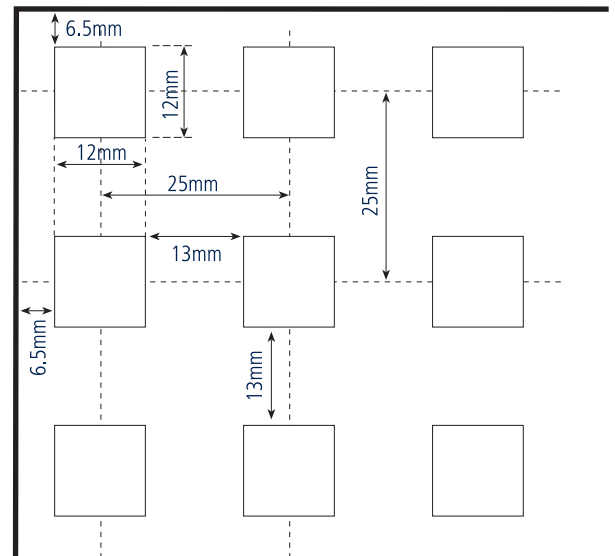

CHARACTERISTICS

Perforation Type:	12mm/25mm
Board Thickness:	1/2" (12.5mm)
Non-woven Fabric Backing:	Charcoal Gray
Finish:	Unfinished paper face
Open Area:	23.0%
Weight:	1.76 lbs / s.f.

AVAILABLE BOARD SIZES

- 1200 mm x 2000 mm (~47.24" x 78.74")
- 1200 mm x 2400 mm (~47.24" x 94.49")
- 1200 mm x 2700 mm (~47.24" x 106.3")
- 900 mm x 2700 mm (~35.43" x 106.3")*

*Limited to stock on hand

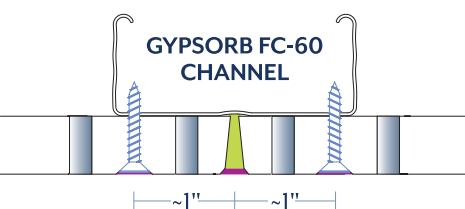

Joints are filled with **GypSorb Ready Mix joint compound** then skimmed over with **standard finishing compound**. Once dry, the joints are sanded smooth in order to receive prime and paint. See *Sonus/Strata Installation Principles* for further information.

SONUS SQUARE 12/25

All Sonos patterns are interchangeable and can be rotated

